

# Specification

## SelfCookingCenter® SCC XS 6 2/3 E (6 x 2/3 GN)

**Reference number:**



**iCookingControl® - 7 operating modes**



**Function - Automatic-Mode**

iCookingControl with the 7 applications for meat, poultry, fish, side dishes, egg dishes & baked goods. Finishing, to easily enter the desired result with automatic adjustment of the ideal cooking path.

**Combi-Steamer mode**



Steam between 30 °C and 130 °C



Hot-air from 30 °C-300 °C



Combination of steam and hot-air  
30 °C-300 °C

**HiDensityControl®**



Patented distribution of the energy in the cooking cabinet

**iLevelControl ILC**



Mixed loads with individual monitoring of every rack depending on the type and quantity of the load as well as the number of door openings.

**Efficient CareControl**



Efficient CareControl recognises soiling and scale and removes it automatically.

**Description**

- Cooking appliance for automatically cooking (Automatic mode) meat, poultry, fish, side dishes/vegetables, egg dishes/desserts, bakery products and for automatic finishing®. With an intelligent system for optimising mixed loads in production and in à la carte service as well as a fully automatic cleaning and care system.
- Hot-air steamer (combi-steamer mode) conforming to DIN 18866 for most of the cooking methods used in commercial kitchens for the optional use of steam and hot-air, individually, in succession or in combination.

**Working safety**

- Detergent and Care tabs (solid detergents) for optimum working safety
- HACCP data output and software update via the integrated Ethernet and USB port
- Safety temperature limiter for steam generator and hot-air heating
- VDE approved for unsupervised operation
- Maximum rack height 1.60 m for use on an original base cabinet
- Integral fan impeller brake
- Door handle with right/left and slam function

**Operation**

- Remote control function for appliance using software and mobile app
- iCC-Cockpit – graphically supported overview of the current cooking chamber climate, the expected progress of the cooking process, review and forecast as well as options at the end of cooking
- iCC Messenger – informs on current and automatic adjustments to the cooking process
- iCC Monitor – Overview of all automatic adjustments to the cooking process
- 9 self-configurable, user-specific operating display (images, text, etc.)
- Record mode – Determination of the ideal cooking path for calibrated products using the core temperature probe for subsequent use without a core temperature probe, with automatic consideration of load quantity
- Self-learning operation, automatically adapts to actual usage
- 8.5" TFT color monitor and touch screen with self-explanatory symbols for ease of operation
- Control second unit from the main unit (units must be connected via ethernet or network)
- Application and user manuals can be called up on the unit display for the current actions

**Cleaning, care and operational safety**

- Automatic cleaning and care system for cooking cabinet and steam generator works regardless of the water pressure supplied
- 7 cleaning stages for unsupervised cleaning and care - even overnight
- Automatic cleaning and descaling of the steam generator
- Automatic cleaning prompts indicating the cleaning stage and volume of chemicals in relation to the level of soiling
- Soiling and care status are displayed on the monitor
- Diagnostic system with automatic service notices displayed
- Self-Test function for actively checking unit's functions

**Features**

- Rear-ventilated triple-glazed cooking cabinet door, two hinged inside panes (for easy cleaning) with a special heat-reflecting coating
- LED cooking cabinet and rack lighting - energy-saving, durable and low-maintenance
- Unit base with surrounding seal
- Lengthwise loading for 2/3, 1/2, 1/3 GN accessories
- Removable, swivel hinging rack with flexible rack options on 11 levels
- Core temperature probe using 6 measuring points with automatic error correction. Positioning aid for core temperature probe included
- Climate management - humidity measured, set and regulated to one percent accuracy. Actual humidity in the cooking cabinet can be set and read on the control panel in Combi-Steamer modes
- Individual Programming of at least 1200 cooking programs with up to 12 steps
- Humidification variable in 3 stages from 86°F–500°F (30°C–260°C) in hot air or combination
- Integrated Ethernet and USB port
- High-performance, fresh-steam generator with automatic descaling
- Dynamic air circulation in cooking cabinet with reversing wheel fan with 5 fan speeds, programmable
- Integral, maintenance-free grease extraction system with no additional grease filter
- Operation without a water softener and without additional descaling
- Cool-down function for fast cabinet fan cooling
- Automatic adaptation to the installation location (height, climate, etc.)
- Material inside and out 304 (DIN 1.4301) stainless steel
- Hand shower with automatic retracting system
- Fixed waste water connection conforming to SVGW requirements were permitted
- Demand-related energy supply
- 5 programmable proofing stages
- Automatic, pre-selected starting time with adjustable date and time

**Approval/Labels**



**Planner/Designer:**



# Specification/Data sheet

Sun Feb 18 13:47:11 CET 2018

## SelfCookingCenter® SCC XS 6 2/3 E (6 x 2/3 GN)

### Technical Info

**Lengthwise loading for:** 2/3, 1/2, 1/3 GN  
**Capacity (GN-container/ grids):** 6 x 2/3 GN  
**Width:** 655 mm  
**Depth:** 623 mm  
**Height:** 567 mm  
**Weight (net):** 72 kg

**Water connection (pressure hose):** 3/4" / d 1/2"  
**Water pressure (flow pressure):** 150-600 kPa / 0,15-0,6 Mpa / 1,5 - 6 bar  
**Water drain:** DN 40 mm  
**Connected load electric :** 5,7 kW  
**"Steam" connection:** 5,4 kW

**"Hot-air" connection:** 5,4 kW

| Mains connection      | Breaker Size / (amp draw) | Cable crossection       |
|-----------------------|---------------------------|-------------------------|
| 3 NAC 400V<br>50/60Hz | 3x10 A                    | 5 x 1,5 mm <sup>2</sup> |

Other voltage on request!

### Installation

- Recommended left hand clearance for service and maintenance 20" / 500 mm. It must be a minimum of 14" / 350 mm if heat sources are affecting the left side of the unit
- Installations must comply with all local electrical, plumbing and ventilation codes. The local standards and regulations for ventilation systems must be adhered to.

### Options

- Left hinged door
- Potential free contact for operation indication included
- Safety door lock
- Connection to energy optimising systems + Potential free contact for operation indication included
- Special voltages

### Accessories

- UltraVent XS condensation hood
- Integration kit incl. UltraVent condensation hood
- GN Containers, Trays, Grids
- Stand
- Special Cleaner tablets and care tabs
- Signal lamp
- Wall mounting to mount the appliance

## SelfCookingCenter® SCC XS 6 2/3 E (6 x 2/3 GN)

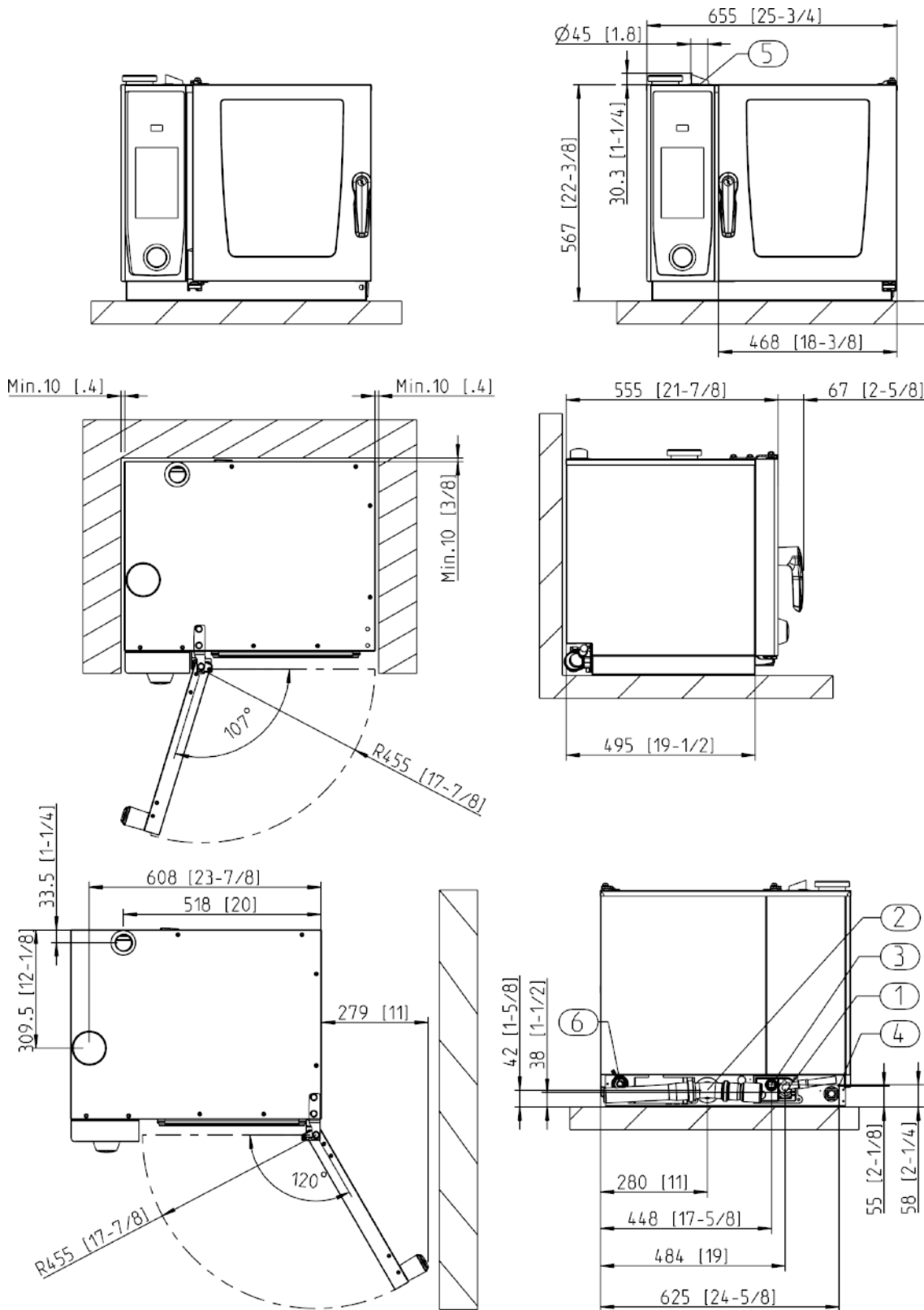

1. Common water supply (cold water) "Single" water connection as shipped 2. Drain 2" OD 3. Electrical connection wire entrance 4. Chassis Ground connection 5. Steam Vent pipe 2 3/8" / 60mm Minimum Clearance 2" / 50 mm Left side clearance 20" recommended for servicing of unit without the ability to move unit while connected. Measurements in mm (inch)